



TechData

MATERIAL SPECIFICATION SHEET



Zero Lead Bronze Check Valve Model 2974ZL*

Description

- Zero Lead Bronze Body
- ProPress Ends
- Spring Check
- EPDM Seals
- .5 PSI Cracking Pressure

Features

- Low Pressure Loss
- Silent Operation
- Stainless Steel Spring
- POM Check

Ratings

- 400 WOG
- Max. Operating Pressure: 200 PSI
- Temperature Range: 0°F - 180°F

Approvals

- Conforms to MSS SP-80
- NSF-61 Annex G
- Conforms to California AB 1953 and Vermont Act 193



Pressure Drop

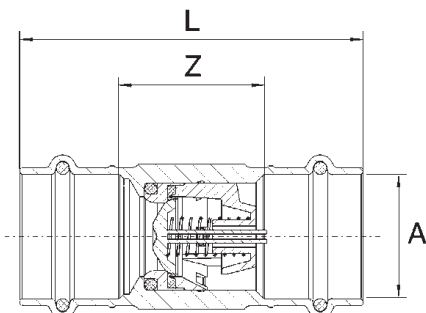
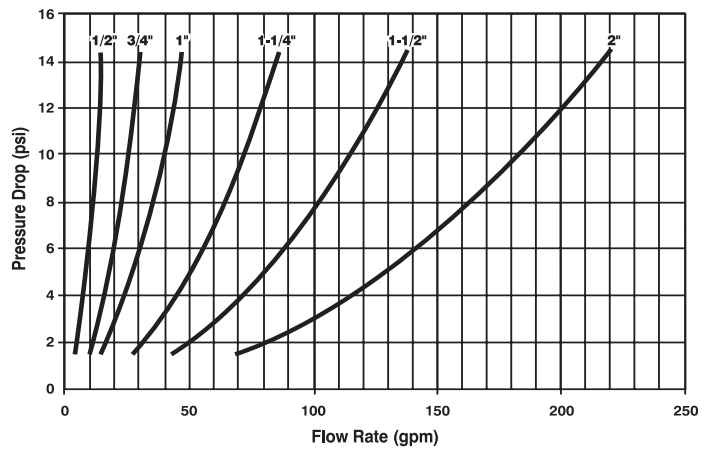

Stock Code	A	L (in)	Z (in)
22353	1/2"	2.362	0.866
22358	3/4"	2.953	1.142
22363	1"	3.150	1.339
22368	1-1/4"	3.740	1.693
22373	1-1/2"	4.921	2.087
22378	2"	5.709	2.559

*ZERO LEAD identifies Viega products meeting the lead free requirements of California and Vermont law, effective January 1, 2010, as tested and listed against NSF- 61, Annex G



VIEGA
301 N. Main, 9th Floor
Wichita, KS 67202
Phone: 1-800-976-9819
Fax: 1-800-976-9817

service@viega.com
www.viega.com